

**Installation Instruction  
EPP-1935-11/11**

**Screened Separable Elbow  
Connector 400 A for  
Bushing Profile Type B  
in accordance to EN 50181  
and Single Core Polymeric  
Insulated Cable with  
Wire Shield  
36 kV**

**Type: RSES-64xx**

**Safety Warning:**

**It is essential to observe the  
applicable safety regulations  
for working with high voltage  
equipment.**

**For precise safety information  
please contact the responsible  
authority.**

**Tyco Electronics Raychem GmbH**  
a TE Connectivity Ltd. Company  
TE Energy  
Finsinger Feld 1  
85521 Ottobrunn/Munich, Germany  
Tel: +49-89-6089-0  
Fax: +49-89-6096-345  
energy.te.com

# Before Starting

Check to ensure that the kit you are going to use fits the cable.

Refer to the kit label and the title of the installation instruction.

Components or working steps may have been improved since you last installed this product.

Carefully read and follow the steps in the installation instruction.

## Kit Contents

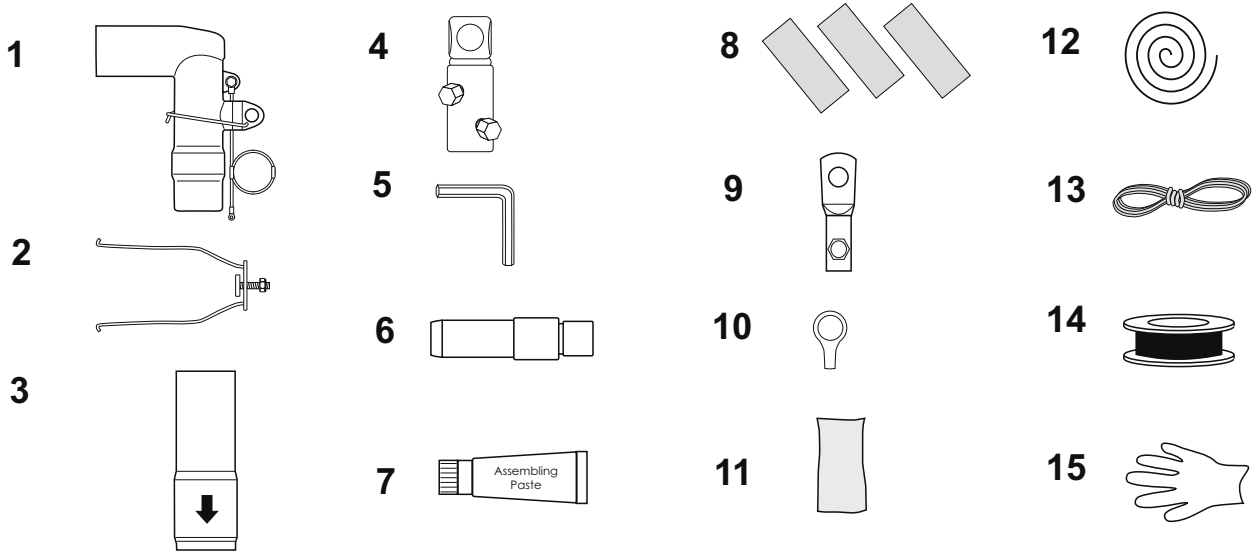

- |   |                    |   |                      |    |  |    |                  |
|---|--------------------|---|----------------------|----|--|----|------------------|
| 1 | 3 x Connector body | 4 | 3 x Main cable lug   | 8  | 3 x Sealing tape (grey)                      | 12 | 1 x Binding wire |
| 2 | 3 x Bail restraint | 5 | 3 x Allen key        | 9  | 3 x Earth cable lug (25–70 mm <sup>2</sup> ) | 13 | 1 x String       |
| 3 | 3 x Stress cone    | 6 | 3 x Contact pin      | 10 | 3 x Screen cable lug                         | 14 | 1 x PVC-tape     |
|   |                    | 7 | 1 x Assembling paste | 11 | 3 x Protective bag                           | 15 | 3 x Gloves       |

Cross Section mm <sup>2</sup>	Ø Core Insulation 24 kV		Reference No. Al/Cu	Cross Section mm <sup>2</sup>	Ø Core Insulation 36 kV		Reference No. Al/Cu
	min	max			min	max	
70–95	22.4–35.5		RSES-6451	50–95	22.4–35.5		RSES-6451
95–240			RSES-6452	95–150			RSES-6452
185–300			RSES-6454	120–240	RSES-6453		
				185–300	28.9–42.0		RSES-6455

The Information contained in these installation instructions is for use only by installers trained to make electrical power installations and is intended to describe the correct method of installation for this product. However, TE Connectivity has no control over the field conditions which influence product installation.

It is the user's responsibility to determine the suitability of the installation method in the user's field conditions. TE Connectivity's only obligations are those in TE Connectivity's standard Conditions of Sale for this product and in no case will TE Connectivity be liable for any other incidental, indirect or consequential damages arising from the use or misuse of the products.

Raychem, TE Connectivity and TE connectivity (logo) are trademarks.

© 2011 Tyco Electronics Raychem GmbH.

# Cable Preparation

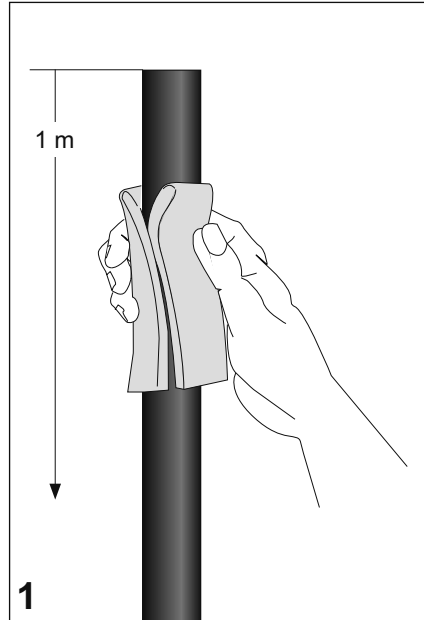

**1**  
Clean and degrease the end of the overshooth for a length of 1 metre with solvent wipe.

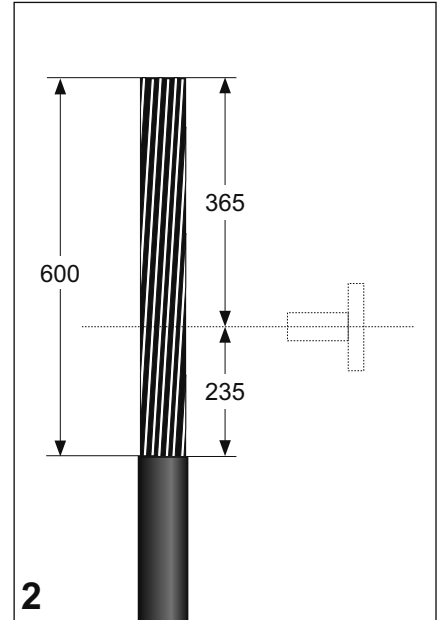

**2**  
**Cable with wire shield**  
Position the cable with sufficient overlap to the bushing centre.  
Mark the overshooth 235 mm below the bushing centre.  
Cut the cable 600 mm above the mark and remove the overshooth over this distance. Cut off Cu-spiral screening tape flush with end of outer sheath.  
**Edges projecting beyond the outer sheath must be avoided**, so that the stress cone cannot be damaged during push on procedure.

Wrap one turn of sealant tape (grey) with no overlap and slight tension around the end of the overshooth.

Cut the tape and push ends together.

Bend the shielding wires back onto the overshooth.

Avoid crossing the individual wires. Temporarily secure the wires with a tape or wire binder.

Cut the core according to the drawing. Remove the core screen with appropriate screen cutting tool according to the drawing. The surface of the insulation should be free from all traces of conductive material. Compare the diameter over insulation with application range as shown in **Table 1** as well as with marking of supplied stress cone.

Cut back the insulation according to dimension **K** given in drawing details.

### Mechanical lugs

Dimension **K** is identical to depth of bore. Barrel butts against insulation.

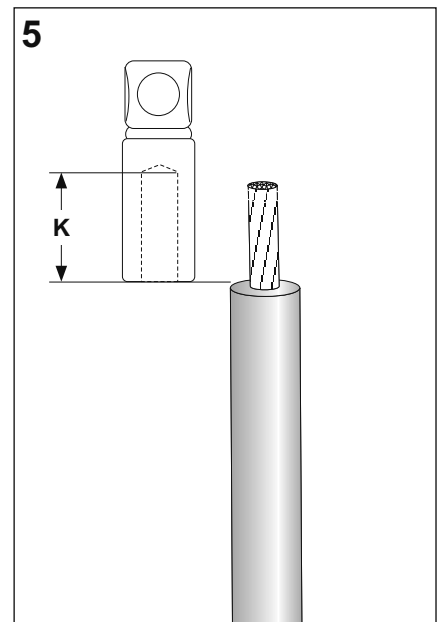
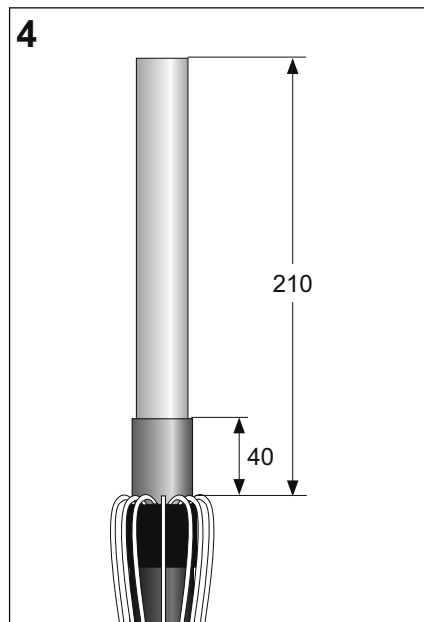
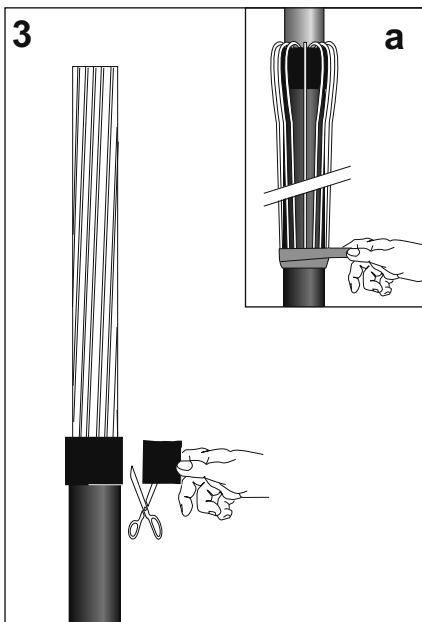

# Core Preparation

Table 2 – Use of inserts

Cross Section (Stranded mm <sup>2</sup> (RM))	Lug Type		
	BLMC-25/95-14	BLMC-95/240-14	BLMC-185/300-14
35	YES		-
50	YES		-
70	NO		-
95	NO	YES	-
120	-	YES	-
150	-	YES	-
185	-	NO	YES
240	-	NO	YES
300	-	-	NO

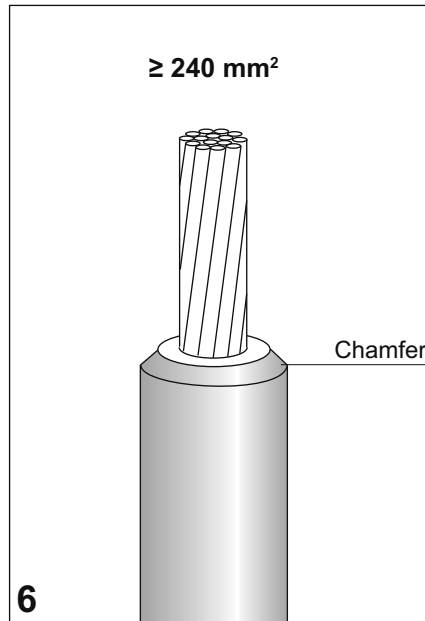

### Recommendation for large cross sections

Convenient push on process of the stress cone requires chamfering of the insulation for cross section 240 mm<sup>2</sup> and above. See drawing!

Apply onto the inner surface of the stress cone at the bottom end a 3 cm long sausage of assembly grease and spread it evenly over the inner surface. Use assembly grease without sponge top. Push the stress cone in one sequence with a twisting movement over the assembly aid completely onto the insulation until the inner collar of the stress cone stops at the oversheath cut back of the cable.

**Note:** The arrow on the stress cone should point onto the cable sheath. Remove the assembly aid from the conductor.

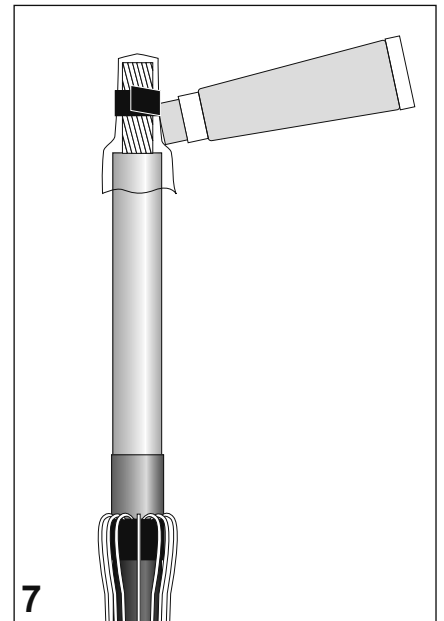

Slide the small protective bag (assembly aid) over the exposed conductor and tie it down with a PVC tape as shown in the drawing. Gently lubricate the outer surface of the protective bag and the core insulation with a thin layer of assembly grease. Apply the grease layer with the sponge top as shown.

### Mechanical lugs with inserts

The insert has to be used as noted in **Table 2**.

Ensure that the retention of the insert is locked into the appropriate hole in the barrel. Align the palm hole with the bushing centre.

Install the cable lug using a lug fixture. Tighten the bolt set alternately in several equal steps until the heads shear off.

**Remove any sharp edges.**

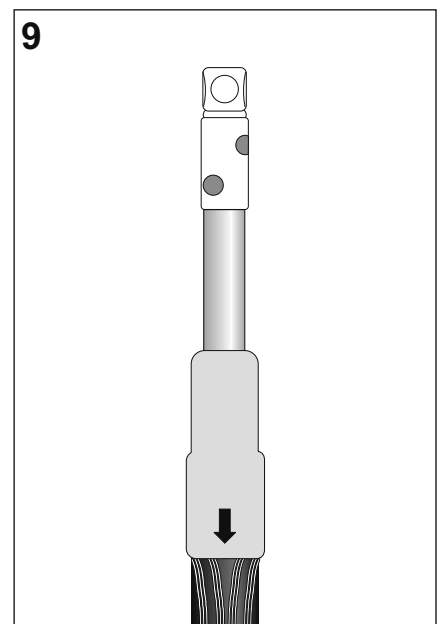
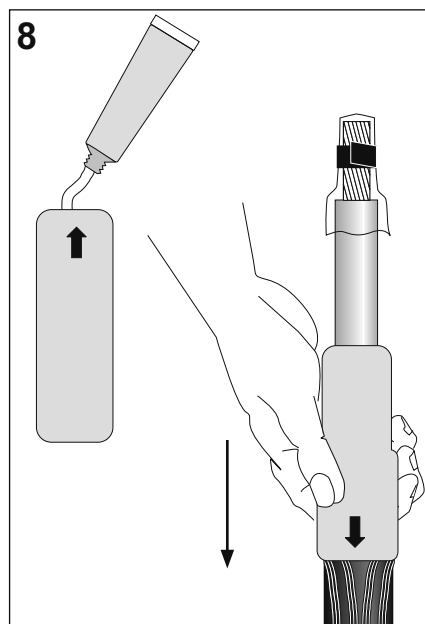

## Mounting of connector body

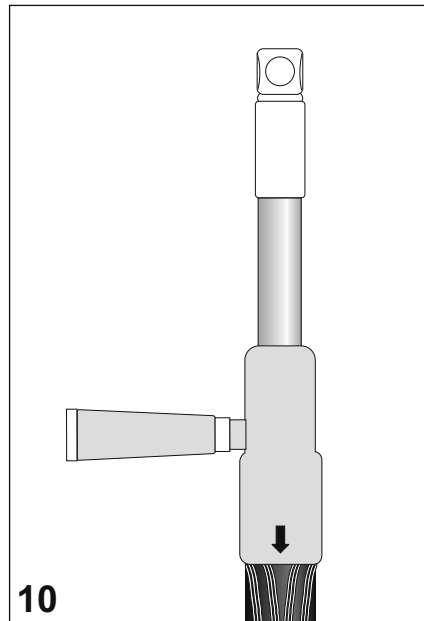

10 Apply a thin layer of grease onto the outer surface of the stress cone with the sponge top.

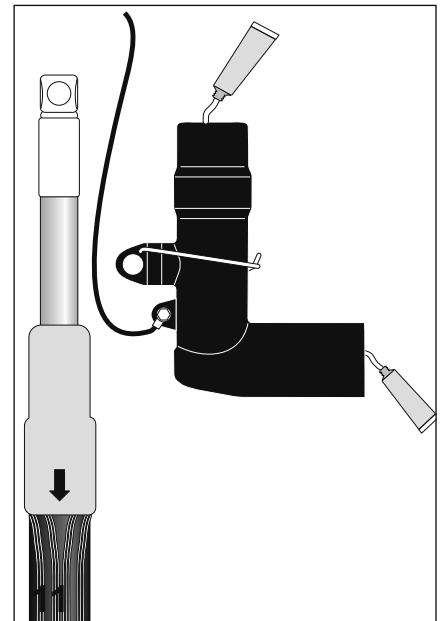

Clean and degrease the bottom and front end of the screened connector body and apply a thin layer of grease onto the inner surface without the sponge top as shown.

**Note:** Use one way glove to evenly lubricate the inner surface at a length of approximately 50 mm.

Push screened connector body with no interruption onto the stress cone and hold it. Continue **immediately** with the next step.

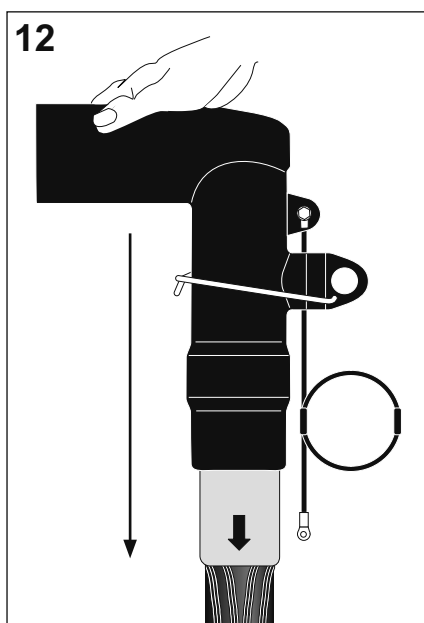

Insert the contact pin into the elbow and fasten it with the Allen key. Apply enough torque until the Allen key is deformed.

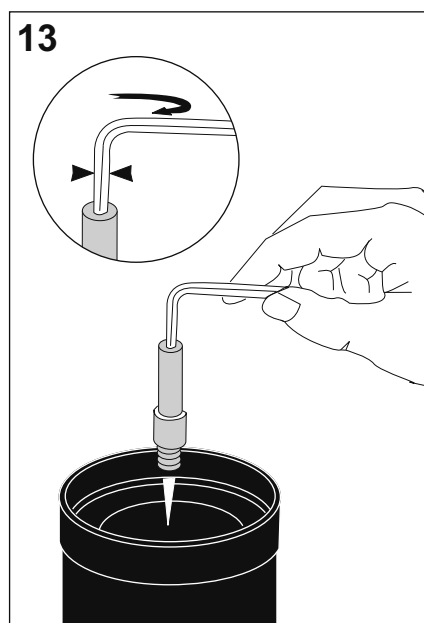

Clean the conical surface of the bushing and lubricate it with the assembly grease as shown.

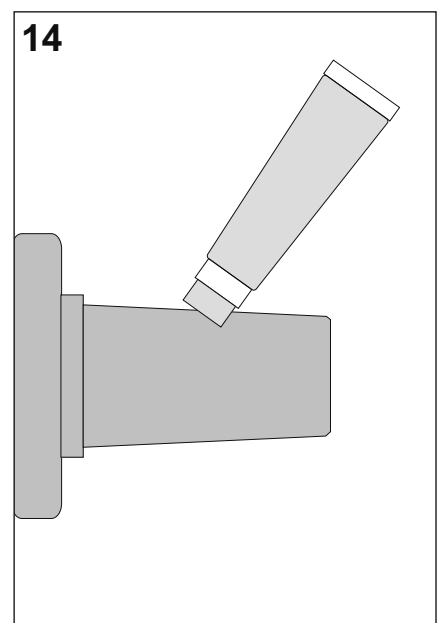

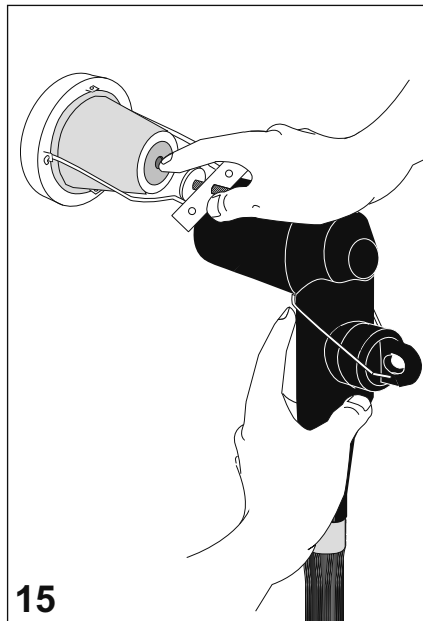

**15**

Insert the hooks of the bail restraint into the eyes of the bushing latch. Align front end of elbow with bushing centre and slide the elbow onto the bushing.

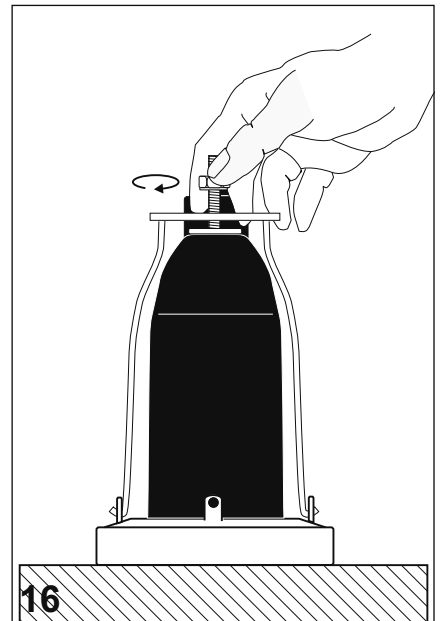

**16**

Place the bail restraint over the elbow until the positioning plate mates its proper groove. Add two additional turns of the nut for final fixation of the product.

Ensure that the grounding lead is fastened tightly.

Fix the shielding wires with a wire binder (four layers) at the end of the stress cone. Gather the wires together to form an earth lead. Install the connection lug supplied in the kit at the end of the shielding wires.

**Perform connection to ground.**

**Screened separable connector completed.**

**Please dispose of all waste according to environmental regulations.**

